

END COVER COLOR: BLACK

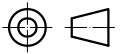
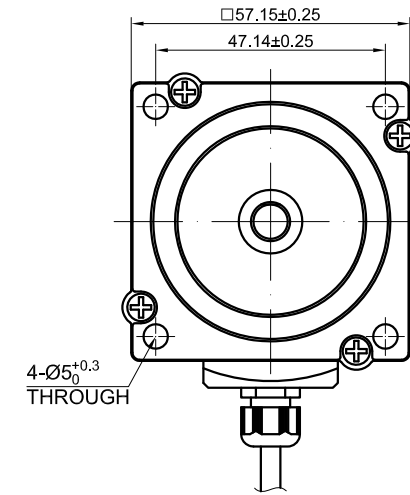
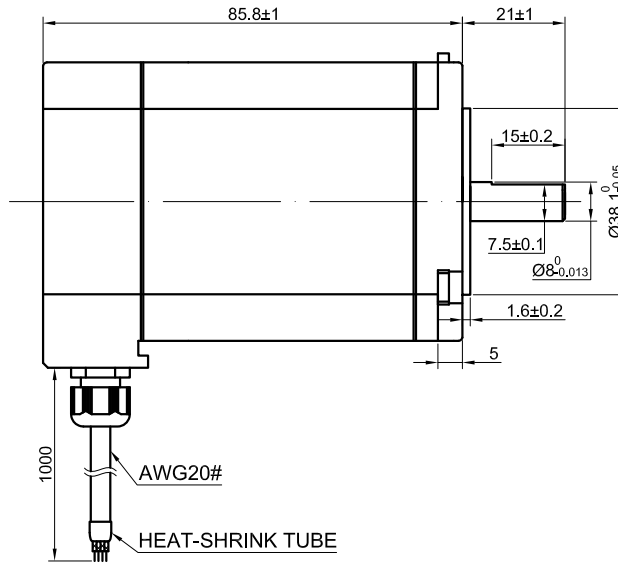
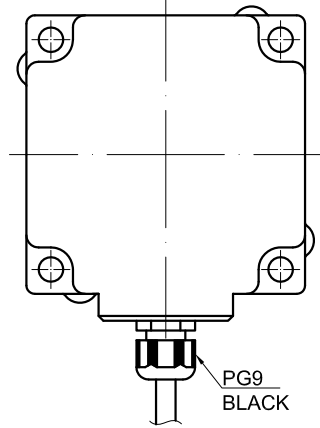

| SPECIFICATION  | CONNECTION | BIPOLAR      |
|--|------------|--------------|
| AMPS/PHASE   |            | 5.00         |
| RESISTANCE/PHASE(Ohms)@20°C  |            | 0.44±10%     |
| INDUCTANCE/PHASE(mH)@1KHz  |            | 1.80±20%     |
| HOLDING TORQUE(Nm)[lb-in]  |            | 2.00 [17.71] |
| STEP ANGLE(°)  |            | 1.8±0.09     |
| MAXIMUM RADIAL RUNOUT(mm)@LOAD 450g  |            | 0.025        |
| MAXIMUM AXIAL RUNOUT(mm)@LOAD 920g   |            | 0.075        |
| ROTOR INERTIA(g-cm <sup>2</sup> )  |            | 480          |
| WATERPROOF GRADE   |            | IP65         |
| WEIGHT(Kg)[lb]   |            | —            |
| TEMPERATURE RISE:MAX.80°C (MOTOR STANDSTILL;FOR 2PHASE ENERGIZED)                |            |              |
| OPERATION AMBIENT TEMPERATURE 0°C~50°C[ 32°F~122°F]                              |            |              |
| INSULATION RESISTANCE 100 Mohm (UNDER NORMAL TEMPERATURE AND HUMIDITY)           |            |              |
| INSULATION CLASS B 130°C[266°F]  |            |              |
| DIELECTRIC STRENGTH 500VAC FOR 1MIN.(BETWEEN THE MOTOR COILS AND THE MOTOR CASE) |            |              |

| TYPE OF CONNECTION (EXTERN) |         | MOTOR |         |
|-----------------------------|---------|-------|---------|
| PIN NO                      | BIPOLAR | LEADS | WINDING |
| 1                           | A —     | BLK   | A       |
| 2                           | A\ —    | GRN   | A\      |
| 3                           | B —     | RED   | B       |
| 4                           | B\ —    | BLU   | B\      |

FULL STEP 2 PHASE-Ex ,  
WHEN FACING MOUNTING END (X)

| STEP | A | B | A\ | B\ | CCW | CW |
|------|---|---|----|----|-----|----|
| 1    | + | + | -  | -  | ↓   | ↑  |
| 2    | - | + | +  | -  |     |    |
| 3    | - | - | +  | +  |     |    |
| 4    | + | - | -  | +  |     |    |

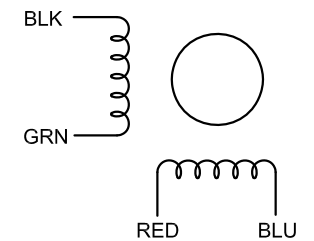

|       |           |      |           |
|-------|-----------|------|-----------|
|       | APVD      |      | 7.12.2019 |
|       | CHKD      |      |           |
| 1:1.5 | DRN       |      |           |
| SCALE | SIGNATURE | DATE |           |

**STEPPER MOTOR**

**23IP65-20**