

SPECIFICATION	CONNECTION	UNIPOLAR
VOTAGE(VOC)		4.40
AMPS/PHASE		2.00
RESISTANCE/PHASE(Ohms)@25°C		2.20±10%
INDUCTANCE/PHASE(mH)@1KHz		7.00±20%
HOLDING TORQUE(Nm)[lb-in]		2.20[19.47]
STEP ANGLE(°)		1.80
STEP ACCURACY(NON-ACCUM)		±5.00%
ROTOR INERTIA(g-cm ²)		1400.00
WEIGHT(Kg)[lb]		1.70[3.75]
TEMPERATURE RISE:MAX.80°C (MOTOR STANDSTILL;FOR 2PHASE ENERGIZED)		
AMBIENT TEMPERATURE -10°C~50°C[14°F~122°F]		
INSULATION RESISTANCE 100 Mohm (UNDER NORMAL TEMPERATURE AND HUMIDITY)		
INSULATION CLASS B 130°C[266°F]		
DIELECTRIC STRENGTH 500VAC FOR 1MIN.(BETWEEN THE MOTOR COILS AND THE MOTOR CASE)		
AMBIENT HUMIDITY MAX.85%(NO CONDENSATION)		

STEP	A	B	\bar{A}	\bar{B}	O(\bar{O})	CW
1	+	+			+	
2		+	+		+	
3			+	+	+	
4	+			+	+	
1	+	+			+	

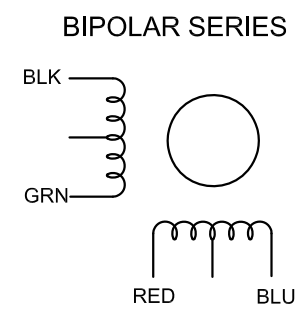
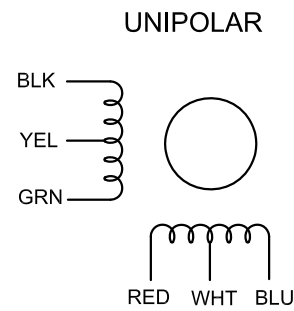

	APVD		
	CHKD		
1:1.5	DRN		
SCALE	SIGNATURE	DATE	

STEPPER MOTOR

34HS26-2006D