

User's Manual
For
DM542T
Full Digital Stepper Drive

©2017 All Rights Reserved Attention: Please read this manual
carefully before using the drive!

Table of Contents

1. Introductions, Features and Applications.....	1
Introductions.....	1
Features.....	1
Applications.....	1
2. Specifications.....	1
Electrical Specifications ($T_j = 25^{\circ}\text{C}/77^{\circ}\text{F}$).....	1
Operating Environment and other Specifications.....	2
Mechanical Specifications (unit: mm [1inch=24.5mm]).....	2
Elimination of Heat.....	2
3. Pin Assignment and Description.....	3
Connector P1 Configurations.....	3
Connector P2 Configurations.....	3
4. Control Signal Connector (P1) Interface.....	3
Connections of 4-lead Motor.....	4
Connections of 6-lead Motor.....	4
Half Coil Configurations.....	4
Full Coil Configurations.....	5
Connections of 8-lead Motor.....	5
Series Connections.....	5
Parallel Connections.....	5
5. Power Supply Selection.....	6
Regulated or Unregulated Power Supply.....	6
Multiple Drives.....	6
Selecting Supply Voltage.....	6
6. Selecting Microstep Resolution and drive Output Current.....	6
Microstep Resolution Selection.....	6
Current Settings.....	7
Dynamic Current Setting.....	7
Standstill Current Setting.....	8
7. Wiring Notes.....	8
8. Typical Connection.....	8
9. Sequence Chart of Control Signals.....	9
10. Protection Functions.....	9
11. Frequently Asked Questions.....	10
Problem Symptoms and Possible Causes.....	10

1. Introductions, Features and Applications

Introductions

The DM542T is a fully digital stepper drive developed with advanced DSP control algorithm based on the latest motion control technology. It has achieved a unique level of system smoothness, providing optimal torque and nulls mid-range instability. Its motor auto-identification and parameter auto-configuration feature offers quick setup to optimal modes with different motors. Compared with traditional analog drives, DM542T can drive a stepper motor at much lower noise, lower heating, and smoother movement. Its unique features make DM542T an ideal choice for high requirement applications.

Features

- Anti-Resonance provides optimal torque and nulls mid-range instability
- Motor auto-identification and parameter auto-configuration when power on, offer optimal responses with different motors
- Multi-Stepping allows a low resolution step input to produce a higher microstep output, thus offers smoother motor movement
- 15 selectable microstep resolutions including 400, 800, 1600, 3200, 6400, 12800, 25600, 1000, 2000, 4000, 5000, 8000, 10000, 20000, 25000
- Soft-start with no “jump” when powered on
- Input voltage 20-50VDC
- 8 selectable peak current including 1.00A, 1.46A, 1.91A, 2.37A, 2.84A, 3.31A, 3.76A, 4.20A
- Pulse input frequency up to 200 KHz, TTL compatible and optically isolated input
- Automatic idle-current reduction
- Suitable for 2-phase and 4-phase motors
- Support PUL/DIR mode
- Over-voltage and over-current protections

Applications

Suitable for a wide range of stepper motors, size from NEMA17 to 24. It can be used in various kinds of machines, such as X-Y tables, engraving machines, labeling machines, laser cutters, pick-place devices, and so on. Particularly adapt to the applications with low noise, low heating, high speed and high precision.

2. Specifications

Electrical Specifications ($T_j = 25^\circ\text{C}/77^\circ\text{F}$)

Parameters	DM542T			Unit
	Min	Typical	Max	
Output Peak Current	1.0	-	4.2 (3.0 RMS)	A
Input Voltage Logic	+20	+36	+50	VDC
Signal Current Pulse	7	10	16	mA
input frequency Pulse	0	-	200	kHz
Width	2.5	-	-	uS
Isolation resistance	500			MΩ

Operating Environment and other Specifications

Cooling	Natural Cooling or Forced cooling	
Operating Environment	Environment	Avoid dust, oil fog and corrosive gases
	Ambient Temperature	0°C – 65°C
	Humidity	40%RH – 90%RH
	Operating Temperature	-10°C – 45°C
	Vibration	10-50Hz / 0.15mm
Storage Temperature	-20°C – 65°C	
Weight	Approx. 210g (7.4oz)	

Mechanical Specifications (unit: mm [1inch=25.4mm])

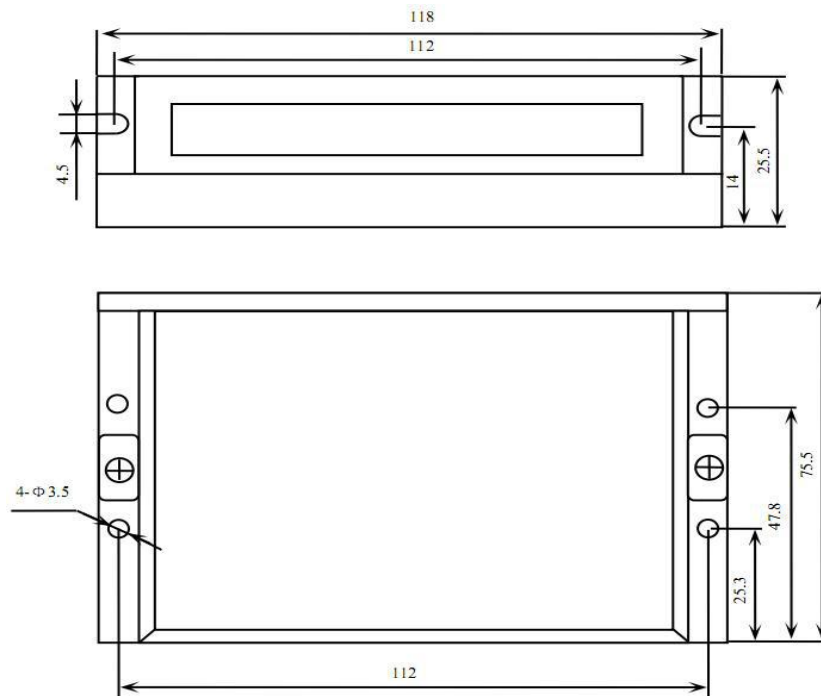

Figure 1: Mechanical specifications

***Recommend use side mounting for better heat dissipation**

Elimination of Heat

- Drive's reliable working temperature should be <math><45^{\circ}\text{C}</math> (113 °F), and motor working temperature should be <math><80^{\circ}\text{C}</math> (176°F);
- It is recommended to use automatic idle-current mode, namely current automatically reduce to 50% when motor stops, so as to reduce drive heating and motor heating;
- It is recommended to mount the drive vertically to maximize heat sink area. Use forced cooling method to cool the system if necessary.

3. Pin Assignment and Description

The DM542T has two connectors P1&P2, P1 is for control signals connections, and P2 is for power and motor connections. The following tables are brief descriptions of the two connectors. More detailed descriptions of the pins and related issues are presented in section 4, 5, 9.

Connector P1 Configurations

Pin Function	Details
PUL+	<u>Pulse signal</u> : In single pulse (pulse/direction) mode, this input represents pulse signal, each rising edge active; 4-5V when PUL-HIGH, 0-0.5V when PUL-LOW. The DM542T drive has no double pulse mode (pulse/pulse). For reliable response, pulse width should be longer than 2.5 μ s. Series connect resistors for current-limiting when +12V or +24V used (1K for +12V, 2k for +24V). The same as DIR and ENA signals.
PUL-	
DIR+	<u>DIR signal</u> : In single-pulse mode, this signal has low/high voltage levels, representing two directions of motor rotation; The DM542T drive has no double pulse mode (pulse/pulse). 4-5V when DIR-HIGH, 0-0.5V when DIR-LOW. Please note that rotation direction is also related to motor-drive wiring match. Exchanging the connection of two wires for a coil to the drive will reverse motor direction.
DIR-	
ENA+	<u>Enable signal</u> : This signal is used for enabling/disabling the drive. High level (NPN control signal, PNP and Differential control signals are on the contrary, namely Low level for enabling.) for enabling the drive and low level for disabling the drive. Usually left
ENA-	UNCONNECTED (ENABLED).

Connector P2 Configurations

Pin Function	Details
GND	Power Ground.
+V	Power supply, 20~50 VDC, Including voltage fluctuation and EMF voltage.
A+, A-	Motor Phase A
B+, B-	Motor Phase B

4. Control Signal Connector (P1) Interface

The DM542T can accept differential and single-ended inputs (including open-collector and PNP output). The DM542T has 3 optically isolated logic inputs which are located on connector P1 to accept line drive control signals. These inputs are isolated to minimize or eliminate electrical noises coupled with the drive control signals. Recommend using line drive control signals to increase noise immunity for the drive in interference environments. In the following figures, connections to open-collector and PNP signals are illustrated.

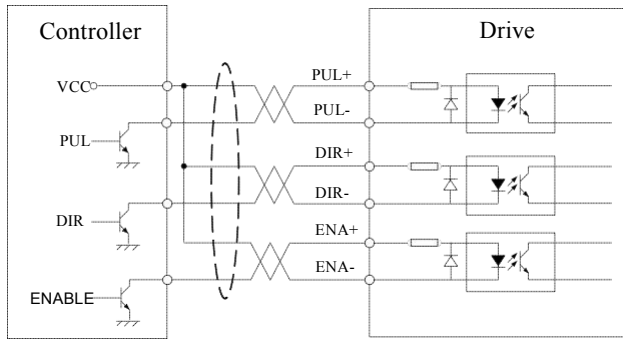

Figure 2: Connections to open-collector signal (common-anode)

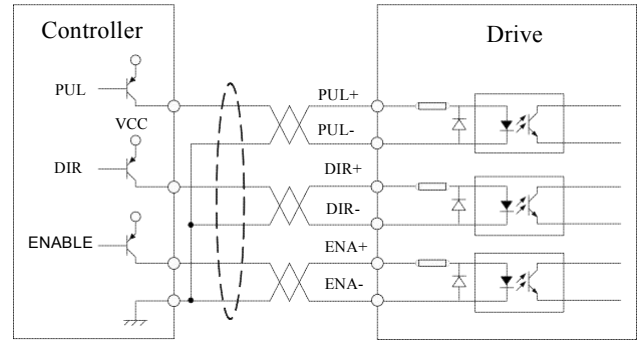

Figure 3: Connections to PNP signal (common-cathode)

Connections of 4-lead Motor

The 4 lead motors are the least flexible and easy to connect. And the Speed – torque of motor depends on winding inductance. The output current from drive that is multiply the specified phase current by 1.4 to determine the peak output current.

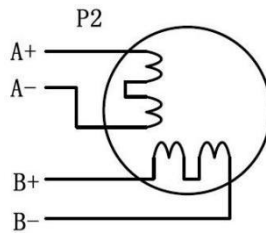

Figure 4: 4-lead Motor Connections

Connections of 6-lead Motor

Like 8 lead stepping motors, 6 lead motors have two configurations available for high speed or high torque operations. The higher speed configuration, or half coil, is described, because it uses one half of the motor’s inductor windings. The higher torque configuration, or full coil, uses the full coil windings.

Half Coil Configurations

As previously stated, the half coil configuration uses 50% of the motor phase windings. This gives lower inductance, hence, lower torque output. Like the parallel connection of 8 lead motor, the torque output will be more stable at higher speeds. This configuration is also referred to as half chopper. In setting the drive output current multiply the specified per phase (or unipolar) current rating by 1.4 to determine the peak output current.

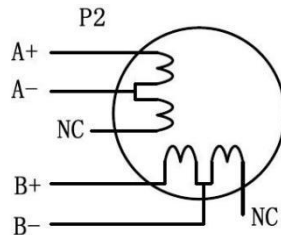

Figure 5: 6-lead motor half coil (higher speed) connections

Full Coil Configurations

The full coil configuration on a six lead motor should be used in applications where higher torque at lower speed is desired. This configuration is also referred to as full copper. In full coil mode, the motors should be run at only 70% of their rated current to prevent overheating.

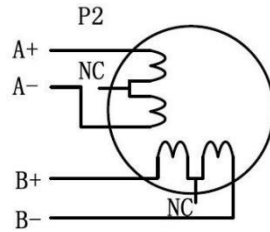

Figure 6: 6-lead motor full coil (higher torque) connections

Connections of 8-lead Motor

8 lead motors offer a high degree of flexibility to the system designer in that they may be connected in series or parallel, thus satisfying a wide range of applications.

Series Connections

A series motor configuration would typically be used in applications where a higher torque at lower speed is required. Because this configuration has the most inductance, the performance will start to degrade at higher speed. In series mode, the motors should also be run at only 70% of their rated current to prevent overheating.

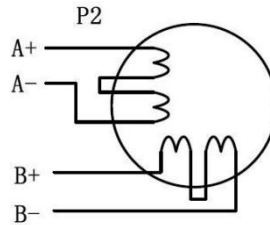

Figure 7: 8-lead motor series connections

Parallel Connections

An 8 lead motor in a parallel configuration offers a more stable, but lower torque at lower speeds. But because of the lower inductance, there will be higher torque at higher speeds. Multiply the per phase (or unipolar) current rating by 1.96, or the bipolar current rating by 1.4, to determine the peak output current.

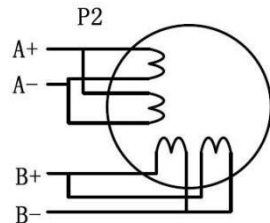

Figure 8: 8-lead motor parallel connections

5. Power Supply Selection

The DM542T can match medium and small size stepping motors (frame size from NEMA17 to 34) made by Leadshine or other motor manufactures around the world. To achieve good driving performances, it is important to select supply voltage and output current properly. Generally speaking, supply voltage determines the high speed performance of the motor, while output current determines the output torque of the driven motor (particularly at lower speed). Higher supply voltage will allow higher motor speed to be achieved, at the price of more noise and heating. If the motion speed requirement is low, it's better to use lower supply voltage to decrease noise, heating and improve reliability.

Regulated or Unregulated Power Supply

Both regulated and unregulated power supplies can be used to supply the drive. However, unregulated power supplies are preferred due to their ability to withstand current surge. If regulated power supplies (such as most switching supplies.) are indeed used, it is important to have large current output rating to avoid problems like current clamp, for example using 4A supply for 3A motor-drive operation. On the other hand, if unregulated supply is used, one may use a power supply of lower current rating than that of motor (typically 50% ~ 70% of motor current). The reason is that the drive draws current from the power supply capacitor of the unregulated supply only during the ON duration of the PWM cycle, but not during the OFF duration. Therefore, the average current withdrawn from power supply is considerably less than motor current. For example, two 3A motors can be well supplied by one power supply of 4A rating.

Multiple Drives

It is recommended to have multiple drives to share one power supply to reduce cost, if the supply has enough capacity. To avoid cross interference, DO NOT daisy-chain the power supply input pins of the drives. (Instead, please connect them to power supply separately.)

Selecting Supply Voltage

The power MOSFETS inside the DM542T can actually operate within +20 ~ +50VDC, including power input fluctuation and back EMF voltage generated by motor coils during motor shaft deceleration. Higher supply voltage can increase motor torque at higher speeds, thus helpful for avoiding losing steps. However, higher voltage may cause bigger motor vibration at lower speed, and it may also cause over-voltage protection or even drive damage. Therefore, it is suggested to choose only sufficiently high supply voltage for intended applications, and it is suggested to use power supplies with theoretical output voltage of +20 ~ +45VDC, leaving room for power fluctuation and back-EMF.

6. Selecting Microstep Resolution and drive Output Current

This drive uses an 8-bit DIP switch to set microstep resolution, and motor operating current, as shown below:

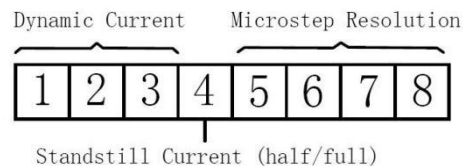

Microstep Resolution Selection

Microstep resolution is set by SW5, 6, 7, 8 of the DIP switches as shown in the following table:

Microstep	Steps/rev.(for 1.8°motor)	SW5	SW6	SW7	SW8
2	400	OFF	ON	ON	ON
4	800	ON	OFF	ON	ON
8	1600	OFF	OFF	ON	ON
16	3200	ON	ON	OFF	ON
32	6400	OFF	ON	OFF	ON
64	12800	ON	OFF	OFF	ON
128	25600	OFF	OFF	OFF	ON
5	1000	ON	ON	ON	OFF
10	2000	OFF	ON	ON	OFF
20	4000	ON	OFF	ON	OFF
25	5000	OFF	OFF	ON	OFF
40	8000	ON	ON	OFF	OFF
50	10000	OFF	ON	OFF	OFF
100	20000	ON	OFF	OFF	OFF
125	25000	OFF	OFF	OFF	OFF

Current Settings

For a given motor, higher drive current will make the motor to output more torque, but at the same time causes more heating in the motor and drive. Therefore, output current is generally set to be such that the motor will not overheat for long time operation. Since parallel and serial connections of motor coils will significantly change resulting inductance and resistance, it is therefore important to set drive output current depending on motor phase current, motor leads and connection methods. Phase current rating supplied by motor manufacturer is important in selecting drive current, however the selection also depends on leads and connections.

The first three bits (SW1, 2, 3) of the DIP switch are used to set the dynamic current. Select a setting closest to your motor's required current.

Dynamic Current Setting

Peak Current	RMS Current	SW1	SW2	SW3
1.00A	0.71A	ON	ON	ON
1.46A	1.04A	OFF	ON	ON
1.91A	1.36A	ON	OFF	ON
2.37A	1.69A	OFF	OFF	ON
2.84A	2.03A	ON	ON	OFF
3.31A	2.36A	OFF	ON	OFF
3.76A	2.69A	ON	OFF	OFF
4.20A	3.00A	OFF	OFF	OFF

Notes: Due to motor inductance, the actual current in the coil may be smaller than the dynamic current setting, particularly under high speed condition.

Standstill Current Setting

SW4 is used for this purpose. OFF meaning that the standstill current is set to be half of the selected dynamic current, and ON meaning that standstill current is set to be the same as the selected dynamic current.

The current automatically reduced to 50% of the selected dynamic current 0.4 second after the last pulse. If the application needs a different standstill current, please contact Leadshine.

Motor auto-identification and parameter auto-configuration

The drive will operate the function of motor auto-identification and parameter auto-configuration when power on, and calculate the optimal parameter using for current control after this processing, then the stepper motor can output optimal torque.

7. Wiring Notes

- In order to improve anti-interference performance of the drive, it is recommended to use twisted pair shield cable.
- To prevent noise incurred in PUL/DIR signal, pulse/direction signal wires and motor wires should not be tied up together. It is better to separate them by at least 10 cm, otherwise the disturbing signals generated by motor will easily disturb pulse direction signals, causing motor position error, system instability and other failures.
- If a power supply serves several drives, separately connecting the drives is recommended instead of daisy-chaining.
- It is prohibited to pull and plug connector P2 while the drive is powered ON, because there is high current flowing through motor coils (even when motor is at standstill). Pulling or plugging connector P2 with power on will cause extremely high back-EMF voltage surge, which may damage the drive.

8. Typical Connection

A complete stepping system should include stepping motor, stepping drive, power supply and controller (pulse generator). A typical connection is shown as figure 9.

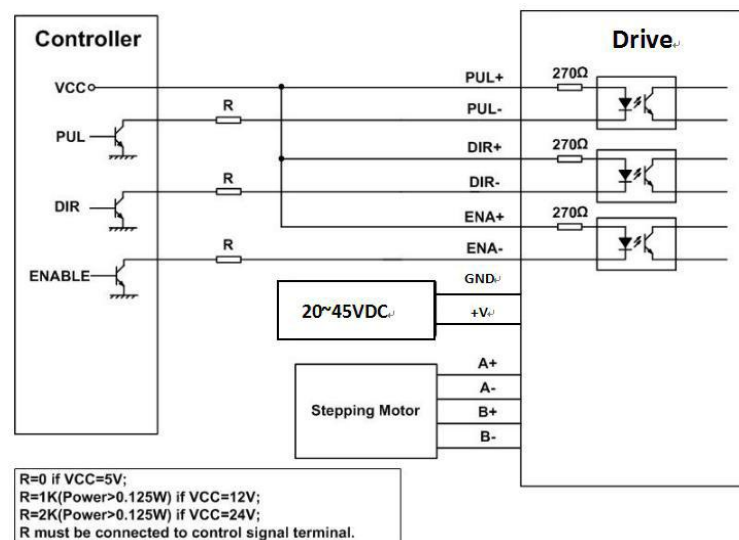

Figure 9: Typical connection

9. Sequence Chart of Control Signals

In order to avoid some fault operations and deviations, PUL, DIR and ENA should abide by some rules, shown as following diagram:

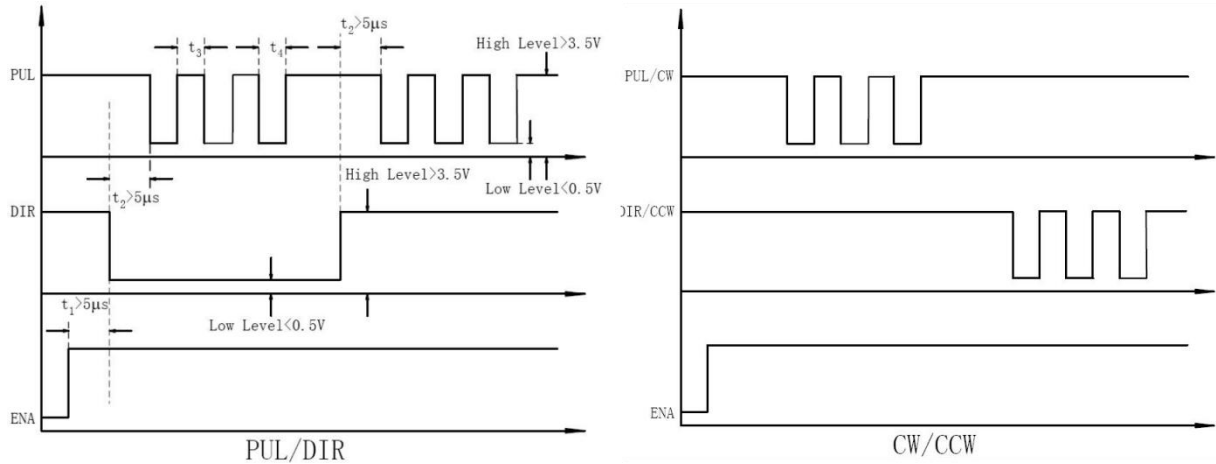

Figure 10: Sequence chart of control signals

Remark:

- t_1 : ENA must be ahead of DIR by at least $5\mu\text{s}$. Usually, ENA+ and ENA- are NC (not connected). See “Connector P1 Configurations” for more information.
- t_2 : DIR must be ahead of PUL effective edge by $5\mu\text{s}$ to ensure correct direction;
- t_3 : Pulse width not less than $2.5\mu\text{s}$;
- t_4 : Low level width not less than $2.5\mu\text{s}$.

10. Protection Functions

To improve reliability, the drive incorporates some built-in protections features.

Priority	Time(s) of Blink	Sequence wave of red LED	Description
1st	1		Over-current protection activated when peak current exceeds the limit.
2nd	2		Over-voltage protection activated when drive working voltage is greater than 60VDC

When above protections are active, the motor shaft will be free or the red LED blinks. Reset the drive by repowering it to make it function properly after removing above problems.

11. Frequently Asked Questions

In the event that your drive doesn't operate properly, the first step is to identify whether the problem is electrical or mechanical in nature. The next step is to isolate the system component that is causing the problem. As part of this process you may have to disconnect the individual components that make up your system and verify that they operate independently. It is important to document each step in the troubleshooting process. You may need this documentation to refer back to at a later date, and these details will greatly assist our Technical Support staff in determining the problem should you need assistance.

Many of the problems that affect motion control systems can be traced to electrical noise, controller software errors, or mistake in wiring.

Problem Symptoms and Possible Causes

Symptoms	Possible Problems
Motor is not rotating	No power
	Microstep resolution setting is wrong
	DIP switch current setting is wrong
	Fault condition exists
Motor rotates in the wrong direction	The drive is disabled
	Motor phases may be connected in reverse
The drive in fault	DIP switch current setting is wrong
	Something wrong with motor coil
	Control signal is too weak
Erratic motor motion	Control signal is interfered
	Wrong motor connection
	Something wrong with motor coil
	Current setting is too small, losing steps
Motor stalls during acceleration	Current setting is too small
	Motor is undersized for the application
	Acceleration is set too high
	Power supply voltage too low
	Inadequate heat sinking / cooling
Excessive motor and drive heating	Automatic current reduction function not being utilized
	Current is set too high