

SPECIFICATION	VALUE
POWER (Kw)	2.2
VOLTAGE (VAC)	110
RATED CURRENT (A)	5
MAXIMUM SPEED (RPM)	24000
FREQUENCY (Hz)	400
NUT MODEL	ER20
COLLET (mm)	Ø6、Ø6.35
RUNOUT OFF (mm)	LESS THAN 0.005
BEARINGS	2x7005 + 2x7002
COOLING	AIR COOLED
MATERIAL	STAINLESS STEEL
LUBRICATION	GREASE
WEIGHT (Kg) [lb]	4.75 [10.47]

P VIEW

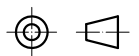
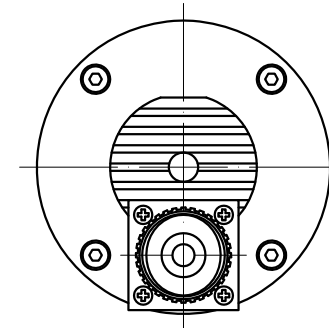

	mm	APVD		5.5.2019
	UNIT	CHKD		
	2:1	DRN		
	SCALE	SIGNATURE		DATE

SPINDLE MOTOR

GDZ80F-2.2A4