Integrated Servo Motor ***ISV Series***



BLDC Servo Motor + Drive, 24-50VDC, Frame 57mm ,90W-180W

<i>Chapter 1 Introduction</i>	2
1.1 <i>Features and specifications</i>	2
1.2 <i>Mechanical Specifications</i>	3
<i>Chapter 2 Conection</i>	4
2.1 <i>Connectors and Pin Assignment</i>	4
2.2 <i>DIP Switch Settings</i>	5
2.3 <i>RS232 Communication Cable Connections</i>	5
2.4 <i>Typical Connections</i>	6
<i>Chapter 3 Parameter</i>	8
3.1 <i>Parameter List</i>	8
3.2 <i>Parameter function</i>	8
3.2.1 <i>Basic Setting</i>	8
3.2.2 <i>Gain Adjustment</i>	10
3.2.3 <i>Vibration Suppression</i>	12
3.2.4 <i>Velocity Control</i>	12
3.2.5 <i>I/F Monitoring Function</i>	13
3.2.6 <i>Extending setup</i>	15
<i>Chapter 4 Alarm</i>	16
<i>Chapter 5 Run</i>	17
5.1 <i>Inspection Before trial Run</i>	17
5.2 <i>Run</i>	17
5.2.1 <i>Position control</i>	17
5.2.2 <i>Internal speed control</i>	18
<i>Chapter 6 Order information</i>	19
<i>Appendix</i>	19
<i>How to find the hidden parameter</i>	19
<i>Trouble shooting</i>	20

Chapter 1 Introduction

1.1 Features and specifications

iSVxxx integrated servo motor is a 57mm frame size brushless motor integrated with a 16bit encoder and a servo drive. At very compact size and with all components integrated, the iSVxxx can save mounting space, eliminate encoder connection & motor wiring time, reduce interference, and cut/reduce cable and labor costs.

Integrated compact size for saving mounting space & setup time, and reducing electrical interference.

- Step & direction command input for position control
- Compatible mounting size with stepper motor
- Smooth motor movement and excellent response time
- Isolated control inputs of Pulse, Direction
- In-position and fault outputs to external motion controllers for complete system controls
- Over voltage, over-current, and position-error protection

Electrical Specifications

Parameter	Min	Typical	Max	Unit
Input Voltage	20	36	50	VDC
Continuous Current	0	-	6.0	A
Pulse Input Frequency	0	-	0-300	kHz
Pulse Voltage	0	5	24	V
Logic Signal Current	7	10	16	mA
Isolation Resistance	100	-	-	MΩ

Note : The max pulse frequency is software configurable

Operating Environment

Cooling	Natural Cooling or Forced cooling	
Operating Environment	Environment	Avoid dust, oil fog and corrosive gases
	Ambient Temperature	0°C — 40°C (32°F — 104°F)
	Humidity	40%RH — 90%RH
	Operating Temperature (Heat Sink)	70°C (158°F) Max
Storage Temperature	-20°C — 65°C (-4°F — 149°F)	

Motor Specifications

Part Number	ISV57T-090	ISV57T-130	ISV57T-180
Rated Power(W)	90	130	180
Rated Torque(Nm)	0.30	0.45	0.6
Peak Torque(Nm)	0.90	1.1	1.5
Rated Speed(rpm)	3000	3000	3000
Peak Speed(rpm)	4000	4000	4000
Rated Voltage(Vdc)	36	36	36
Weight(kg)	0.95	1.25	1.54

Applications

iSVxxx can be used in various applications such as laser cutters, laser markers, high precision X-Y tables, labeling machines, CNC router, etc. Its unique features make the iSVxxx an ideal choice for applications that require both low-speed smoothness and small mounting space.

1.2 Mechanical Specifications

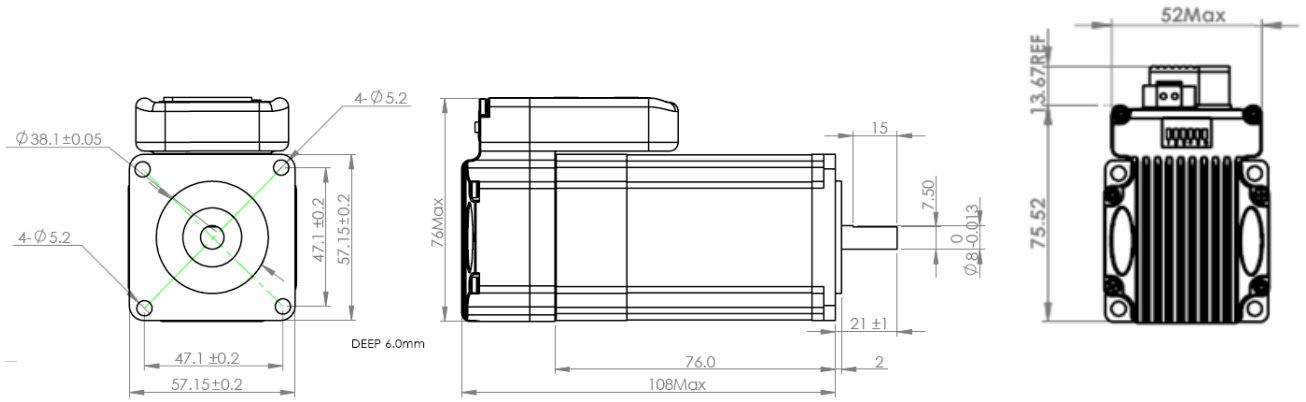

Mechanical Specification of ISV57T-090

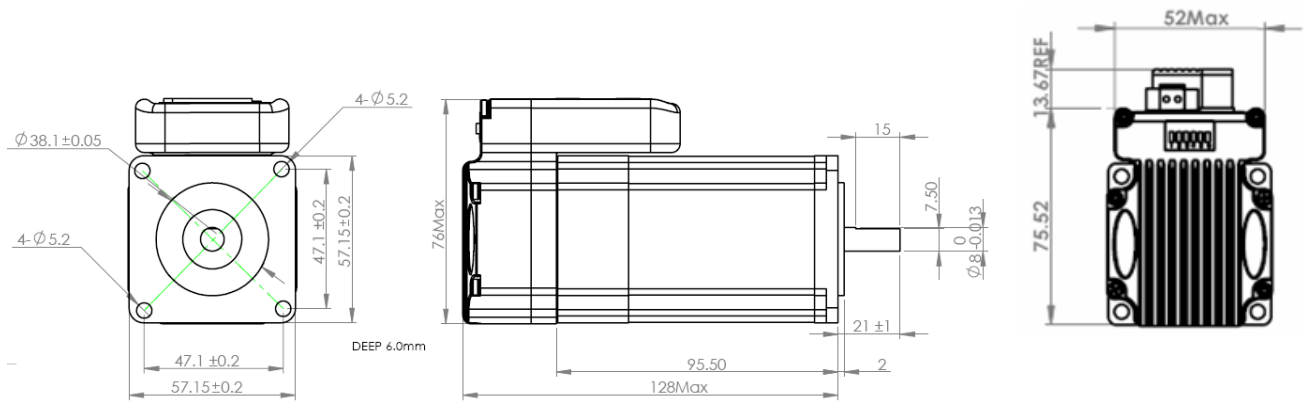

Mechanical Specification of ISV57T-130

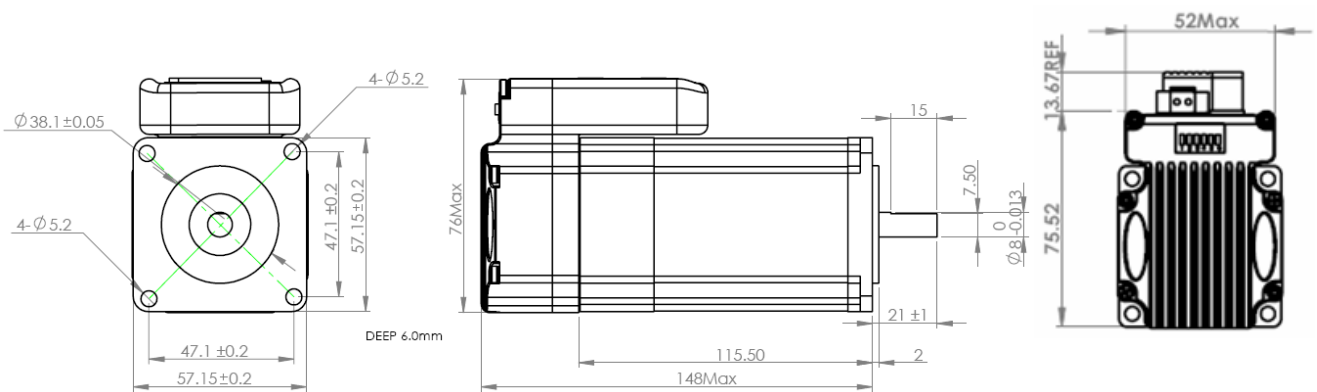

Mechanical Specification of ISV57T-180

Chapter 2 Connection

2.1 Connectors and Pin Assignment

iSVxxx has three connectors, a connector for control signals connections, a connector for RS232 communication connection, and a connector for power connections.

Control Signal Connector				
Pin	Name	I/O	Description	
1	PUL+	I	<u>Pulse Signal</u> : In single pulse (pulse/direction) mode, this input represents pulse signal, active at each rising or falling edge (Software configurable). In double pulse mode (software configurable), this input represents clockwise (CW) pulse, active both at each high level and low level. 4.5-24V for PUL-HIGH, 0-0.5V for PUL-LOW. For reliable response, pulse width should be longer than 2.5 μ s for 200K MAX input frequency or 1 μ s for 500K MAX input frequency.	<p>The fuction of four pins will be different if ISV motor works in internal velocity mode .</p> <p>Pls refer to chapter 3 and chapter 4 about how to use these four pins for velocity mode .</p>
2	PUL-	I		
3	DIR+	I	<u>Direction Signal</u> : In single-pulse mode, this signal has low/high voltage levels, representing two directions of motor rotation. In double-pulse mode (software configurable), this signal is counter-clock (CCW) pulse, active both at high level and low level. For reliable motion response, DIR signal should be ahead of PUL signal by 5 μ s at least. 4.5-24V for DIR-HIGH, 0-0.5V for DIR-LOW. Toggle DIP switch SW5 to reverse motion direction.	
4	DIR-	I		
5	ALM+	O	<u>Alarm Signal</u> : OC output signal, activated when one of the following protection is activated: over-voltage and over current error. They can sink or source MAX 50mA current at 24V. By default, the impedance between ALM+ and ALM- is low for normal operation and becomes high when any protection is activated. The active impedance of alarm signal is software configurable.	
6	ALM-	O		

Power Connector			
Pin	Name	I/O	Description
1	+Vdc	I	Power Supply Input (Positive) 24-36VDC recommended. Please leave reasonable reservation for voltage fluctuation and back-EMF during deceleration.
2	GND	GND	Power Ground (Negative)

RS232 Communication Connector			
Pin	Name	I/O	Description
1	+5V	O	+5V power output (Note: Do not connect it to PC's serial port)
2	TxD	O	RS232 transmit.
3	GND	GND	Ground.
4	RxD	I	RS232 receive.
5	NC	-	Not connected.

2.2 DIP Switch Settings

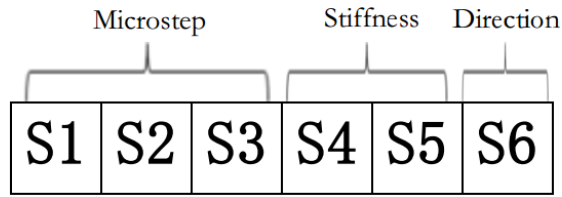

. Pulses/Rev (S1-S3)

Pulse/rev	S1	S2	S3
Pr0.08	Off	Off	Off
1600	On	Off	Off
2000	Off	On	Off
3200	On	On	Off
4000	Off	Off	On
5000	On	Off	On
6400	Off	On	On
8000	On	On	On

Stiffness setting(S4—S5)

Stiffness	S4	S5
Pr0.03	Off	Off
72	On	Off
71	Off	On
70	On	On

Motor Shaft Direction (S6)

DIP switch S6 is used for changing motor shaft rotation direction. Changing position from “ON” to “OFF”, or “OFF” to “ON” will reverse iSVxxx rotation direction.

S6	Direction
Off	CCW
On	CW

2.3 RS232 Communication Cable Connections

Note1: The RS232 communication port is not isolated. Please use an isolated power supply for the ISVxxx when the PC’s serial port is not isolated.

Note2: Do not plug or unplug the connector when power is on.

2.4 Typical Connections

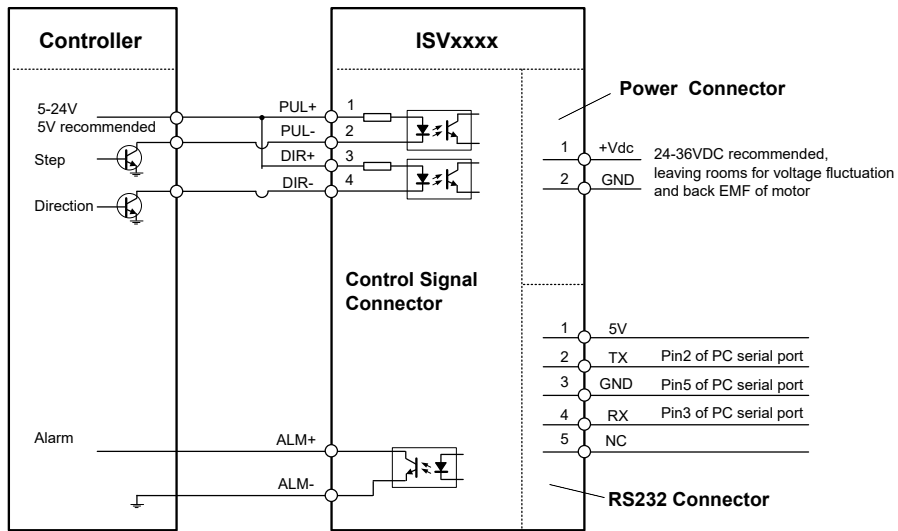

Connect iSVxxx to controller of sinking output

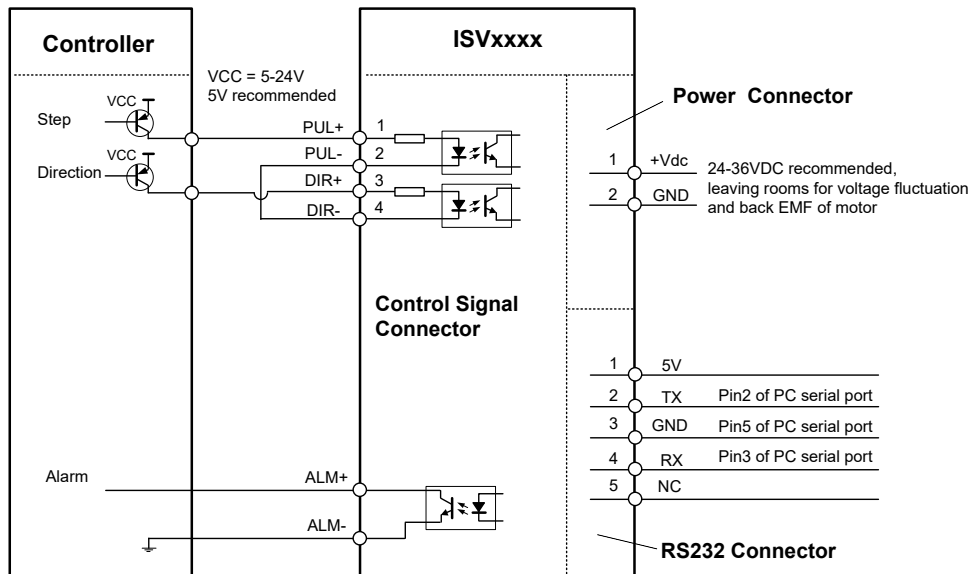

Connect iSVxxx to controller of sourcing output

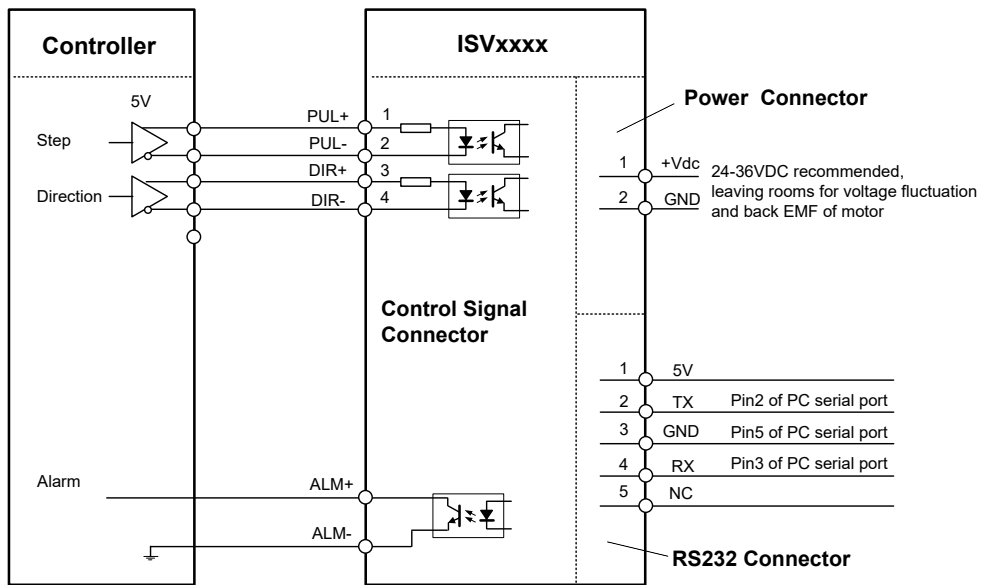

Connect iSVxxx to controller of differential output

Chapter 3 Parameter

3.1 Parameter List

Num	Name	Range	Default	Unit
Pr0.01	Control mode setup	20 ~ 21	20	--
Pr0.02	Real-time auto-gain tuning	0 ~ 2	1	--
Pr0.03	Selection of machine stiffness at real-time auto-gain tuning	50 ~ 81	70	--
Pr0.04	Inertia ratio	0 ~ 10000	300	%
Pr0.06	Command pulse rotational direction setup	0 ~ 1	0	--
Pr0.08	Command pulse input mode setup	0 ~ 32767	4096	Pulse
Pr0.13	1st torque limit	0 ~ 500	300	--
Pr0.14	Position deviation excess setup	0 ~ 500	200	0.1rev
Pr0.20	Test result of inertia ratio	0 ~ 32767	0	%
Pr1.00	1st gain of position loop	0 ~ 30000	320	0.1/s
Pr1.01	1st gain of velocity loop	1 ~ 32767	180	0.1Hz
Pr1.02	1st time constant of velocity loop integration	1 ~ 10000	310	0.1ms
Pr1.03	1st filter of velocity detection	0 ~ 10000	15	--
Pr1.10	Velocity feed forward gain	0 ~ 1000	300	0.10%
Pr1.11	Velocity feed forward filter	0 ~ 6400	50	0.01ms
Pr1.37	Register for special function	0 ~ 1	0	--
Pr2.22	positional command smoothing filter	0 ~ 32767	0	0.1ms
Pr3.03	Speed command reversal input	0 ~ 1	0	--
Pr3.04	1st speed setup	-5000 ~ 5000	0	r/min
Pr3.05	2nd speed setup	-5000 ~ 5000	0	r/min
Pr3.06	3rd speed setup	-5000 ~ 5000	0	r/min
Pr3.07	4th speed setup	-5000 ~ 5000	0	r/min
Pr3.12	time setup acceleration	0 ~ 10000	100	ms/(Krpm)
Pr3.13	time setup deceleration	0 ~ 10000	100	ms/(Krpm)
Pr3.24	maximum speed of motor rotation	0 ~ 5000	0	r/min
Pr4.06	input selection SI7	0 ~ 16777215	1200	--
Pr4.07	input selection SI8	0 ~ 16777215	0E00	--
Pr4.08	input selection SI9	0 ~ 16777215	8383	--
Pr4.10	output selection SO1	0 ~ 16777215	1111H	--
Pr4.31	Positioning complete range	0 ~ 10000	10	Pulse
Pr4.35	Velocity coincidence range	10 ~ 2000	50	r/min
Pr4.36	At-speed	10 ~ 2000	1000	r/min
Pr5.13	Over-speed level setup	0 ~ 5000	0	r/min
Pr5.20	Position setup unit select	0 ~ 2	0	--

3.2 Parameter function

3.2.1 Basic Setting

Pr0.01*	Control Mode Setup	Range	unit	default	Related control mode	
		20 -21	-	20	P	S

Setup value	Bit mode
20	Position
21	Velocity

Pr0.02	Real-time Auto-gain Tuning	Range	unit	default	Related control mode	
		0-2	-	1	P	S
You can set up the action mode of the real-time auto-gain tuning.						
Setup value	mode	Varying degree of load inertia in motion				
0	invalid	Real-time auto-gain tuning function is disabled.				
1	standard	Basic mode. do not use unbalanced load, friction compensation or gain switching, mainly used for interpolation movement .				
2	positioning	Main application is positioning. it is recommended to use this mode on equipment without unbalanced horizontal axis, ball screw driving equipment with low friction, etc ,mainly used for point-to-point movement				
Caution: If pr0.02=1 or 2 , you can't modify the values of pr1.01 – pr1.13, the values of them depend on the real-time auto-gain tuning ,all of them are set by the driver itself.						

Pr0.03	selection of machine stiffness at real time auto gain tuning	Range	unit	default	Related control mode	
		50-81	-	70	P	S
You can set up response while the real-time auto-gain tuning is valid.						
<p style="text-align: center;"> Low ———▶ Machine stiffness ———▶ High Low ———▶ Servo gain ———▶ High </p> <div style="border: 1px solid black; padding: 5px; margin: 10px auto; width: 80%;"> 81.80.....70.69.68.....51.50 </div> <p style="text-align: center;"> Low ———▶ Response ———▶ High </p>						
<p>Notice: Higher the setup value, higher the velocity response and servo stiffness will be obtained. However, when increasing the value, check the resulting operation to avoid oscillation or vibration. Control gain is updated while the motor is stopped.</p> <p>For ISV motor , stiffness can be set with switch with SW4,SW5, any change from the SW4,5 will be available after restarting power</p>						

Pr0.04	Inertia ratio	Range	unit	default	Related control mode	
		0-10000	%	300	P	S
You can set up the ratio of the load inertia against the rotor(of the motor)inertia.						
<div style="border: 1px solid black; padding: 5px;"> $Pr0.04 = (\text{load inertia} / \text{rotor inertia}) \times 100\%$ </div> <p>Notice: If the inertia ratio is correctly set, the setup unit of Pr1.01 and Pr1.06 becomes (Hz). When the inertia ratio of Pr0.04 is larger than the actual value, the setup unit of the velocity loop gain becomes larger, and when the inertia ratio of Pr0.04 is smaller than the actual value, the setup unit of the velocity loop gain becomes smaller.</p>						

Pr0.06*	Command Pulse Rotational Direction Setup	Range	unit	default	Related control mode	
		0-1	-	0	P	
Set command pulse input rotate direction, command pulse input type						
Pr0.07*	Command Pulse Input Mode Setup	Range	unit	default	Related control mode	
		0-3	-	3	P	

Pr0.06	Pr0.07	Command Pulse Format	Signal	Positive Direction Command	Negative Direction Command
0	0 or 2	90 phase difference 2-phase pulse(A phase+B phase)	Pulse sign		
	1	Positive direction pulse+ negative direction pulse	Pulse sign		
	3	Pulse + sign	Pulse sign		
1	0 or 2	90 phase difference 2 phase pulse(A phase+B phase)	Pulse sign		
	1	Positive direction pulse+ negative direction pulse	Pulse sign		
	3	Pulse + sign	Pulse sign		

Command pulse input signal allow largest frequency and smallest time width

PULS/SIGN Signal Input I/F		Permissible Max. Input Frequency	Smallest Time Width					
			t1	t2	t3	t4	t5	t6
Pulse series interface	Long distance interface	500kpps	2	1	1	1	1	1
	Open-collector output	200kpps	5	2.5	2.5	2.5	2.5	2.5

Pr0.08	Command pulse counts per one motor revolution	Range	unit	default	Related control mode	
		0-32767	pulse	0	P	

Set the command pulse that causes single turn of the motor shaft.
When this setting is 0, Pr009 1st numerator of electronic gear and Pr0.10 Denominator of electronic Gear become valid.

Pr0.20	Display value of inertia ratio	Range	unit	default	Related control mode	
		0-32767	%	0	P	S

Notice:

Pr0.04=Pr020-100

This value is read only for display the inertia value, this is used for setting the value of Pr004.

3.2.2 Gain Adjustment

Pr1.00	1st gain of position loop	Range	unit	default	Related control mode	
		0-30000	0.1/s	320	P	

You can determine the response of the positional control system. Higher the gain of position loop you set, faster the positioning time you can obtain. Note that too high setup may cause oscillation.

Pr1.01	1st gain of velocity loop	Range	unit	default	Related control mode	
		0-32767	0.1Hz	180	P	S

You can determine the response of the velocity loop. In order to increase the response of overall servo system by setting high position loop gain, you need higher setup of this velocity loop gain as well. However, too high setup may cause oscillation.

Pr1.02	1st Time Constant of Velocity Loop Integration	Range	unit	default	Related control mode	
		0-10000	0.1ms	310	P	S

You can set up the integration time constant of velocity loop, Smaller the set up, faster you can dog-in deviation at stall to 0. The integration will be maintained by setting to "9999". The integration

effect will be lost by setting to "10000".

Pr1.03	1st Filter of Velocity Detection	Range	unit	default	Related control mode	
		0 -31	-	15	P	S

You can set up the time constant of the low pass filter (LPF) after the speed detection, in 32 steps (0 to 31). Higher the setup, larger the time constant you can obtain so that you can decrease the motor noise, however, response becomes slow.

You can set the filter parameters through the loop gain, referring to the following table:

Set Value	Speed Detection Filter Cut-off Frequency(Hz)	Set Value	Speed Detection Filter Cut-off Frequency(Hz)
72	1200	67	850
71	1100	66	800
70	1000	65	750
69	950	64	700
68	900	63	650

Pr1.10	Velocity feed forward gain	Range	unit	default	Related control mode	
		0 -1000	0.1%	300	P	

Multiply the velocity control command calculated according to the internal positional command by the ratio of this parameter and add the result to the speed command resulting from the positional control process.

Pr1.11	Velocity feed forward filter	Range	unit	default	Related control mode	
		0 -6400	0.01ms	50	P	

Set the time constant of 1st delay filter which affects the input of speed feed forward.

(usage example of velocity feed forward)

The velocity feed forward will become effective as the velocity feed forward gain is gradually increased with the speed feed forward filter set at approx. 50 (0.5ms). The positional deviation during operation at a constant speed is reduced as shown in the equation below in proportion to the value of velocity feed forward gain.

$$\text{Position deviation [unit of command]} = \text{command speed [unit of command /s]} / \text{position loop gain [1/s]} \times (100 - \text{speed feed forward gain [\%]} / 100)$$

Pr1.37	Register for special function	Range	unit	default	Related control mode	
		0 - 1	0.01ms	0	P	S

Do special setting as below :

Setting value	描述
Pr1.37 & 0x01	=0: Velocity Feedforward is available, =1: Velocity Feedforward is forbidden;
Pr1.37 & 0x02	=0: Torque Feedforward is available, =2: Torque Feedforward is forbidden;
Pr1.37 & 0x04	=0: "motor over speed Er1A1" is available, =4: "motor over speed Er1A1" is forbidden;
Pr1.37 & 0x08	=0: "Position following error Er180" is available, =8: "Position following error Er180" is forbidden;
Pr1.37 & 0x10	=0: "Overload Er100" is available, =0x10: "Overload Er100" is forbidden,
Pr1.37 & 0x400	=0: "Under voltage Er0D0" is forbidden =0x400: "Under voltage Er0D0" is available,

3.2.3 Vibration Suppression

Pr2.22	positional command smoothing filter	Range	unit	default	Related control mode	
		0 -32767	0.1ms	0	P	

- Set up the time constant of the 1st delay filter in response to the positional command.
- When a square wave command for the target speed V_c is applied, set up the time constant of the 1st delay filter as shown in the figure below.

Notice: Restart the power to make new value available.

3.2.4 Velocity Control

Pr3.03	Reversal of speed command input	Range	unit	default	Related control mode	
		0 -1	-	0	S	

Specify the polarity of the voltage applied to the analog speed command (SPR).

Setup value	Motor rotating direction	
0	Non-reversal	[+ voltage] → [+ direction] [- voltage] → [- direction]
1	reversal	[+ voltage] → [- direction] [- voltage] → [+ direction]

Caution: When you compose the servo drive system with this driver set to velocity control mode and external positioning unit, the motor might perform an abnormal action if the polarity of the speed command signal from the unit and the polarity of this parameter setup does not match.

Pr3.04	1th speed of speed setup	Range	unit	default	Related control mode	
		-20000 -20000	r/min	0		S
Pr3.05	2th speed of speed setup	Range	unit	default	Related control mode	
		-20000 -20000	r/min	3000		S
Pr3.06	3th speed of speed setup	Range	unit	default	Related control mode	
		-20000 -20000	r/min	0		S
Pr3.07	4th speed of speed setup	Range	unit	default	Related control mode	
		-20000 -20000	r/min	0		S

Set up internal command speeds, 1st to 4th

selection 1 of internal command speed (INTSPD1)	selection 2 of internal command speed (INTSPD2)	selection of Speed command
OFF	OFF	1st speed
ON	OFF	2nd speed
OFF	ON	3rd speed
ON	ON	4th speed

Pr3.12	time setup acceleration	Range	unit	default	Related control mode	
		0 -10000	Ms(1000r/min)	100		S
Pr3.13	time setup deceleration	Range	unit	default	Related control mode	
		0 -10000	Ms(1000r/min)	100		S
<p>Set up acceleration/deceleration processing time in response to the speed command input. Set the time required for the speed command(stepwise input)to reach 1000r/min to Pr3.12 Acceleration time setup. Also set the time required for the speed command to reach from 1000r/min to 0 r/min, to Pr3.13 Deceleration time setup. Assuming that the target value of the speed command is Vc(r/min), the time required for acceleration/deceleration can be computed from the formula shown below. Acceleration time (ms)=Vc/1000 *Pr3.12 *1ms Deceleration time (ms)=Vc/1000 *Pr3.13 *1ms</p>						
Pr3.24	Motor rotate maximum speed limit	Range	unit	default	Related control mode	
		0 -6000	r/min	3000	P	S
Set up motor running max rotate speed, but can't be exceeded motor allowed max rotate speed.						

3.2.5 I/F Monitoring Function

Pr4.06	DIR+/DIR- Input Selection	Range	unit	Default	Related control mode										
		0-00FFFFFFh	-	0x1200		S									
<p>If ISV motor works in position mode , pls make sure Pr406 set as default setting 0x1200. If ISV motor works in velocity mode , pls make sure Pr406 set as below :</p> <table border="1"> <thead> <tr> <th>Signal name</th> <th>symbol</th> <th>value</th> </tr> </thead> <tbody> <tr> <td>Selection 1 input of internal command speed</td> <td>INTSPD1</td> <td>8E**h</td> </tr> <tr> <td>Selection 2 input of internal command speed</td> <td>INTSPD2</td> <td>8F**h</td> </tr> </tbody> </table> <p>For example , Pr406 set as 0x8E00 or 0x8F00 .</p> <p>Notice : 1) Power need to be restarted to make new value available . 2) The value of Pr406 can't be set equally to Pr407.</p>							Signal name	symbol	value	Selection 1 input of internal command speed	INTSPD1	8E**h	Selection 2 input of internal command speed	INTSPD2	8F**h
Signal name	symbol	value													
Selection 1 input of internal command speed	INTSPD1	8E**h													
Selection 2 input of internal command speed	INTSPD2	8F**h													

Pr4.07	PUL+/PUL- Input Selection	Range	unit	Default	Related control mode										
		0-00FFFFFFh	-	0x0E00		S									
<p>If ISV motor works in position mode , pls make sure Pr407 set as default setting 0x0E00. If ISV motor works in velocity mode , pls make sure Pr407 set as below :</p> <table border="1"> <thead> <tr> <th>Signal name</th> <th>symbol</th> <th>value</th> </tr> </thead> <tbody> <tr> <td>Selection 1 input of internal command speed</td> <td>INTSPD1</td> <td>8E**h</td> </tr> <tr> <td>Selection 2 input of internal command speed</td> <td>INTSPD2</td> <td>8F**h</td> </tr> </tbody> </table> <p>For example , Pr406 set as 0x8E00 or 0x8F00 .</p> <p>Notice : 1) Power need to be restarted to make new value available . 2) The value of Pr407 can't be set equally to Pr406.</p>							Signal name	symbol	value	Selection 1 input of internal command speed	INTSPD1	8E**h	Selection 2 input of internal command speed	INTSPD2	8F**h
Signal name	symbol	value													
Selection 1 input of internal command speed	INTSPD1	8E**h													
Selection 2 input of internal command speed	INTSPD2	8F**h													

Pr4.08	Servo on status for enabling	Range	unit	Default	Related control mode	
		0-00FFFFFFh	-	0x8383		S

This parameter set the status of servo on for enabling , enabling means the shaft of motor is lock , disabling means the shaft of motor is free and can be run with hand .

Set value	Details
0x8383	Servo on are ready for both position mode and velocity mode after power on
0x0383	Servo on is ready for position mode ,but not for velocity mode after power on.
0x8303	Servo on is ready for velocity mode ,but not for position mode after power on
0x303	Servo on is unavailable for both position mode and velocity mode after power on

Notice : new value is available without restarting the power .

Pr4.10	Output selection of ALM+/ALM-	Range	unit		Related control mode	
		0-00FFFFFFh	-	0x1111	P	S

Assign functions to SO outputs.
This parameter use 16 binary system do setup, as following :

00- - - * * h: position control
00- * * - - h: velocity control
Please at [**] partition set up function number.

Signal name	symbol	Setup value
Invalid	-	00h
Alarm output(a contact)	Alm	01h
Alarm output(b contact)	Alm	11h
Positioning complete output	INP	04h
At-speed output	AT-SPPED	05h
Velocity coincidence output	V-COIN	08h

Notice : 1) New value will be available imediately .
2) The value of Pr410 can't be set equally to other IO setting .

Pr4.31	Positioning complete range	Range	unit	default	Related control mode	
		0 -10000	Encoder unit	10	P	

Set up the timing of positional deviation at which the positioning complete signal (INP1) is output.

Pr4.35	Velocity coincidence range	Range	unit	default	Related control mode	
		10 -20000	r/min	50		S

Set the speed coincidence (V-COIN) output detection timing.
Output the speed coincidence (V-COIN) when the difference between the speed command and the motor speed is equal to or smaller than the speed specified by this parameter.
Because the speed coincidence detection is associated with 10 r/min hysteresis, actual detection range is as shown below.

Speed coincidence output OFF -> ON timing (Pr4.35 -10) r/min
Speed coincidence output ON -> OFF timing (Pr4.35 +10) r/min

The graph illustrates the velocity coincidence detection logic. The y-axis represents Speed in r/min, and the x-axis represents Time. Three curves are shown: 'Speed command', 'Speed command after acceleration/deceleration process', and 'Motor speed'. The 'Speed command' is a step function. The 'Speed command after acceleration/deceleration process' shows the motor's response, which lags behind the command. The 'Motor speed' is the actual speed of the motor. The 'Speed coincidence output V-COIN' is shown as a digital signal that is ON when the motor speed is within a range of Pr4.35 ± 10 r/min of the speed command. The graph shows the output turning ON during acceleration and OFF during deceleration.

3.2.6 Extending setup

Pr5.13	Over-speed level setup	Range	unit	default	Related control mode	
		0-20000	r/min	0	P	S

If the motor speed exceeds this setup value, Err1A.0[over-speed protect] occurs.
The over-speed level becomes 1.2 times of the motor max, speed by setting up this to 0.

Chapter 4 Alarm

The green light turns on when iSVxxx is powered on and functions normally. In any case that drive protection is activated, the red LED blinks periodically (in every 4 seconds) to indicate the error type. In each blink, red light is on for 0.2 second and then off for 0.3 second.

Priority	Time(s) of Blink	Sequence wave of red LED	Description
1st	1		Hardware Over-current protection activated when peak current is greater than 18A
2nd	2		Over-voltage protection activated when drive working voltage is greater than 60VDC
3rd	3		Software over-current protection
4th	4		Over-load protection
5th	5		Encoder error activated when encoder connection or feedback is not correct
6th	6		number of pole-pairs error activated when the number of pole-pairs setting is wrong
7th	7		Position following error activated when position following error limit exceeded the pre-set value (4000 pulses by default, or value set value by a customer)
8th	1 short 1 long		Motor stall protection
9th	1 short 2 long		Current null shift protection
10th	1 short 3 long		Parameter saving error
11th	1 short 4 long		Others error

ALM	Over current(hardware)	Over voltage	Over current (software)	Overload
Code in Protuner	ErOE1	ErOC0	ErOE0	Er100
LED Blink	1 short	2 short	3 short	4 short

ALM	Enocder err	Poles err	Pos following err	Over speed
Code in Protuner	Er150/Er151	ErOD1	Er180	Er1A0/Er1A1

LED Blink	5 short	6 short	7 short	1 short, 1 long
-----------	---------	---------	---------	-----------------

Chapter 5 Run

5.1 Inspection Before trial Run

No	Item	Content
1	Inspection on wiring	Power cable , tuning cable , signal cable
2	Confirmation of power supply	The voltage between Vdc and Gnd is no more than 36Vdc .
3	Fixing of position	Motor installation
4	Inspection without load	Motor shaft doesn't connect the load

5.2 Run

ISV**** can work in both position mode and internal velocity mode .

5.2.1 Position control

◆ connection

Port	Default
+Vdc	+24V~+36Vdc
GND	Power GND
PUL+/PUL-	Pulse input signal
DIR+/DIR-	Direction input signal
ALM+/ALM-	Alm output signal
SW1	Microstep setting
SW2	Microstep setting
SW3	Microstep setting
SW4	Stiffness selection 1
SW5	Stiffness selection 2
SW6	Running direction

Steps :

Connect the motor with tuning cable (CABLE-PC-i)

a) How to find the ratio of inertia for one axis

It is very important to find ratio of inertia for one axis in order to make best performance before setting other parameter (for example, setting PID of position loop or velocity loop) .

Here below is step to find ratio.

Connect motor with load if you need to test one axis.

Do make the axis can be moved in safe distance, any interference should be avoided to ensure safety and accuracy of testing .

1.1 set the driver working in position loop (pr0.01=20).

1.2 click "run test"  ,then set the following value below :

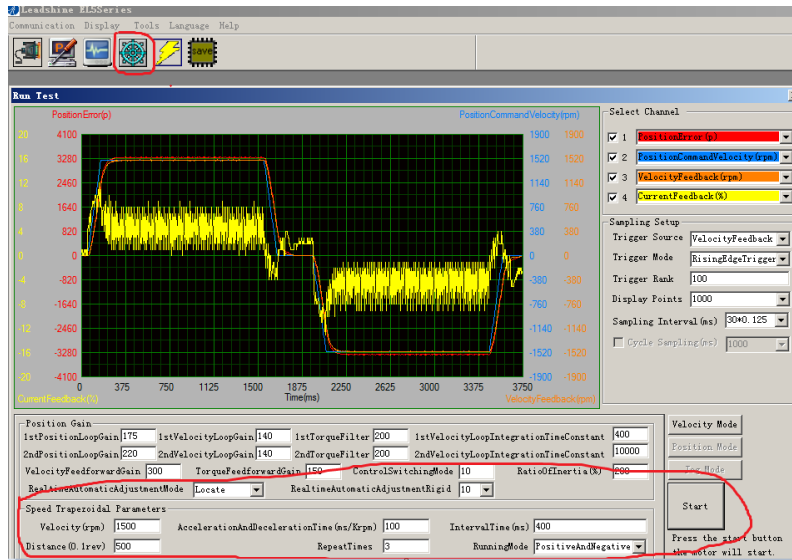

Set RealTimeAutomaticAdjustmentMode as **Manual** ,
 And set RealTimeAutomaticAdjustmentRigid as **70 or 71** .

Then set: Velocity = 1500 rpm, acceleration = 100, interval time = 1000,
 distance = 500 (0.1 rev) Repeat time = 3, RunningMode : Positive and negative

Check the value of Pr020, then minus 100, the result means the value of pr004 .

For example ,

Check the value of Pr020 , if the value is 500, then pr004 = 400 , it means the ratio of inertia equals 4 . (**If you can't find the pr020, refer to appendix "How to find the hidden parameter "**)

b) Set electric ratio

Pr008 can be set for counts per rev if SW1 and SW2 are both OFF .
 Or change the status of SW1 and SW2 to change the counts per rev .

c) set running direction

Both SW6 and Pr006 can be used to set direction of running .

d) download and save the new value , and restart the power to make values available .

5.2.2 Internal speed control

Port		
+Vdc	24-50 Vdc	
GND	Power gnd	
PUL+/PUL-	INTSPD1	Pr4.07=8E00
DIR+/DIR-	INTSPD2	Pr4.06=8F00
ALM+/ALM-	Alm output signal	
SW4	Stiffness selection1	
SW5	Stiffness selection2	

- a) set pr003 and pr004 in position mode (pr001=20)
- b) set pr001=21, set pr407 and pr406 as 8E00 and 8F00
- c) set the velocity value : set pr304=0 ,pr305=1000 , set pr306= -500 , pr307= 1500, there must be one velocity as 0 .
- d) set the value for acceleration and deceleration for Pr312 and Pr313

【INTSPD1】	【INTSPD2】	Velocity value
OFF	OFF	Pr3.04
ON	OFF	Pr3.05
OFF	ON	Pr3.06
ON	ON	Pr3.07

Chapter 6 Order information

Frame (mm)	Output power (W)	Type name	Rated Torque (N.M)	Peak Torque (N.M)
57	90	ISV-B23090T-D4	0.3	0.8
	130	ISV-B23130T-D4	0.45	1.1
	180	ISV-B23180T-D4	0.6	1.5
Cable for Tuning		Cable –PC-i		

Appendix

How to find the hidden parameter

The value of many parameters are forbidden to change , because usually the value has been set properly, however some parameters are needed to be checked or changed, for example , Pr715 need to be changed to match the motor type.

Here is the step to change the value of Pr020:

Run the software of ProTuner , we just find part of the parameter :

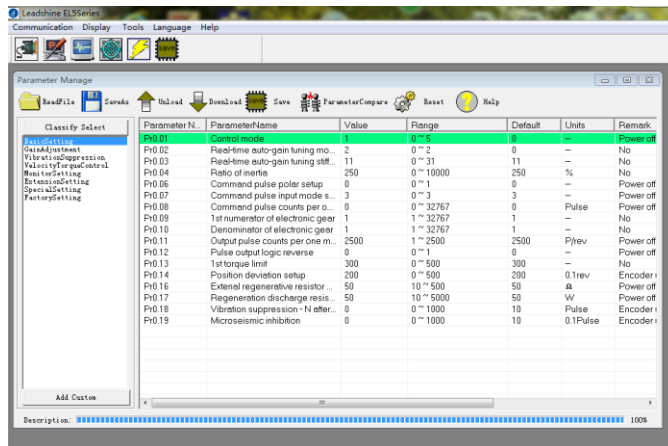

1. Now here is the way to find all of them :

a. Click “factory setting” :

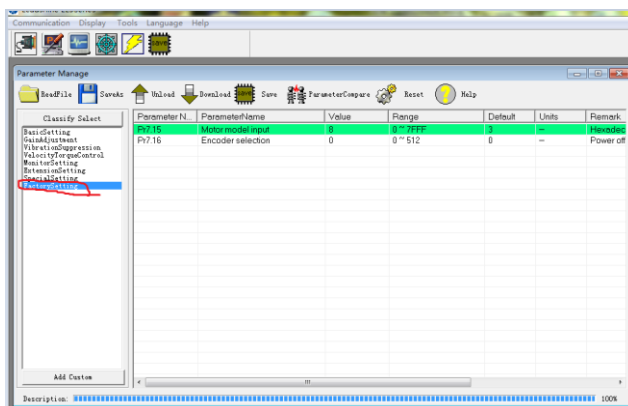

b. Click “description” :

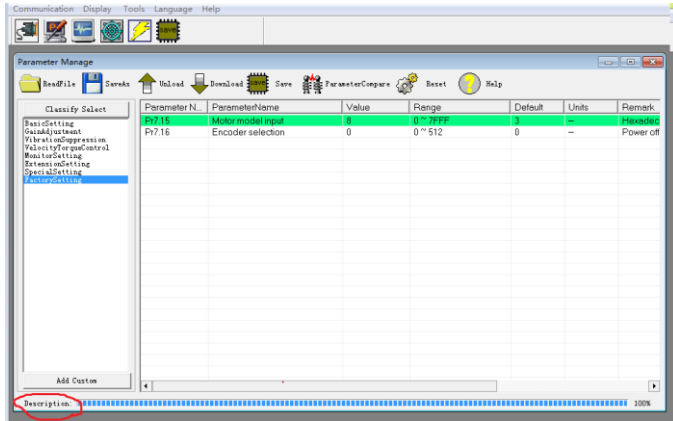

c. Then double click “factorysetting”, then we can find all parameter:

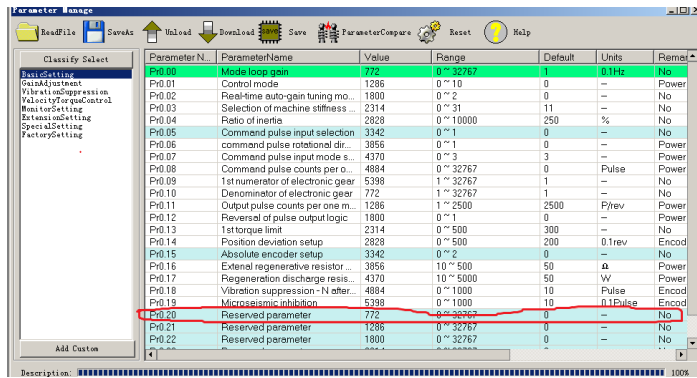

Trouble shooting

Problem	Solution
Motor don't run	<ul style="list-style-type: none"> ◇ If in position mode, : make sure pr408=8383, pr406=1200, pr407=E00; make sure voltage of input signal (pulse + direction) is between 5 - 24V. ◇ If in internal velocity mode : Make sure pr406 and pr407 are 8F** and 8E** ; Make sure pr304=0 Make sure pr408=8383
ALM	Refer to chapter 4 for details
Factory setting can't be set	Change the value of Pr408 to 303 .
The stiffness can't be changed	Check the status of SW3-SW5.